

Top View

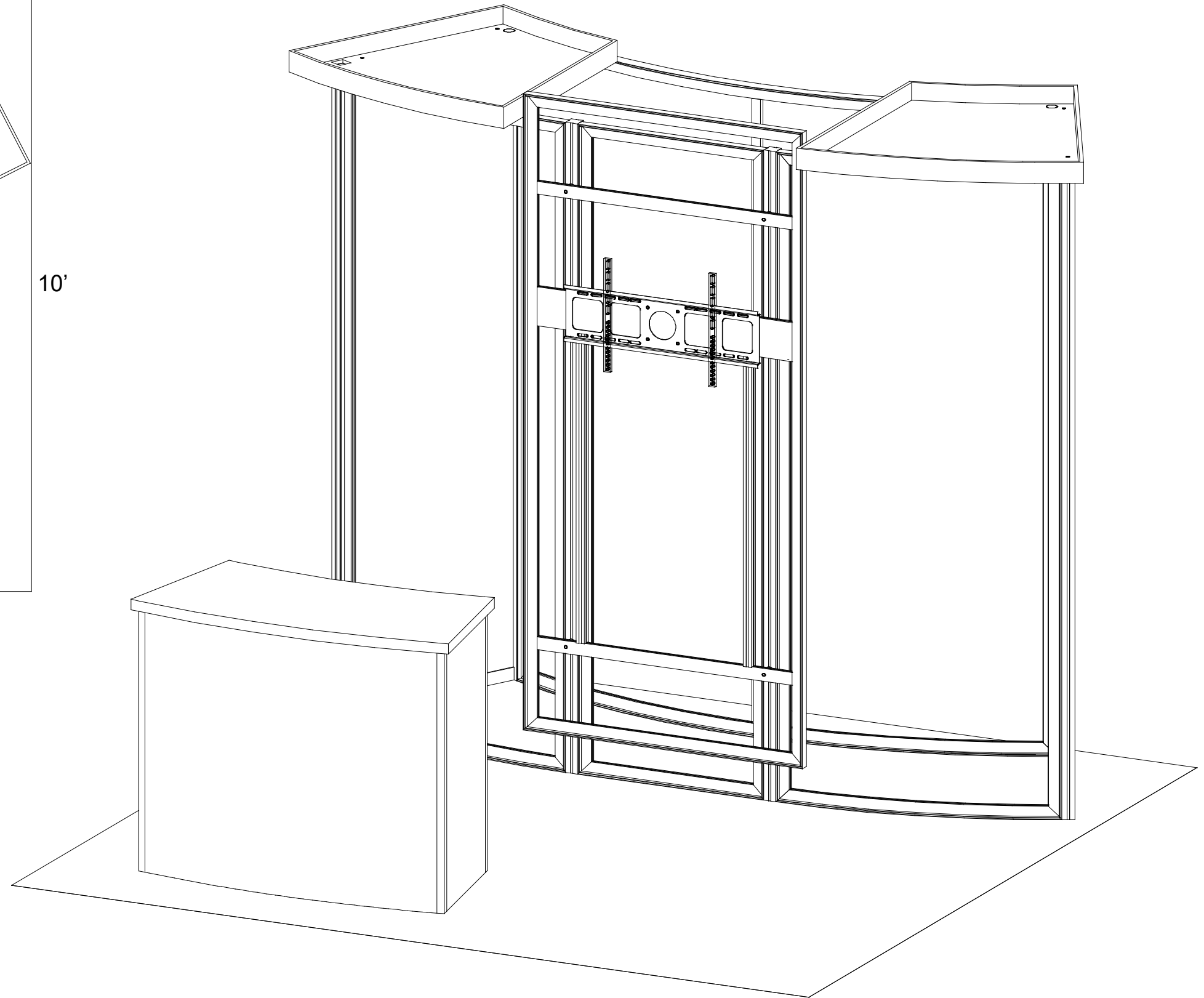

# ***SETUP INSTRUCTIONS***

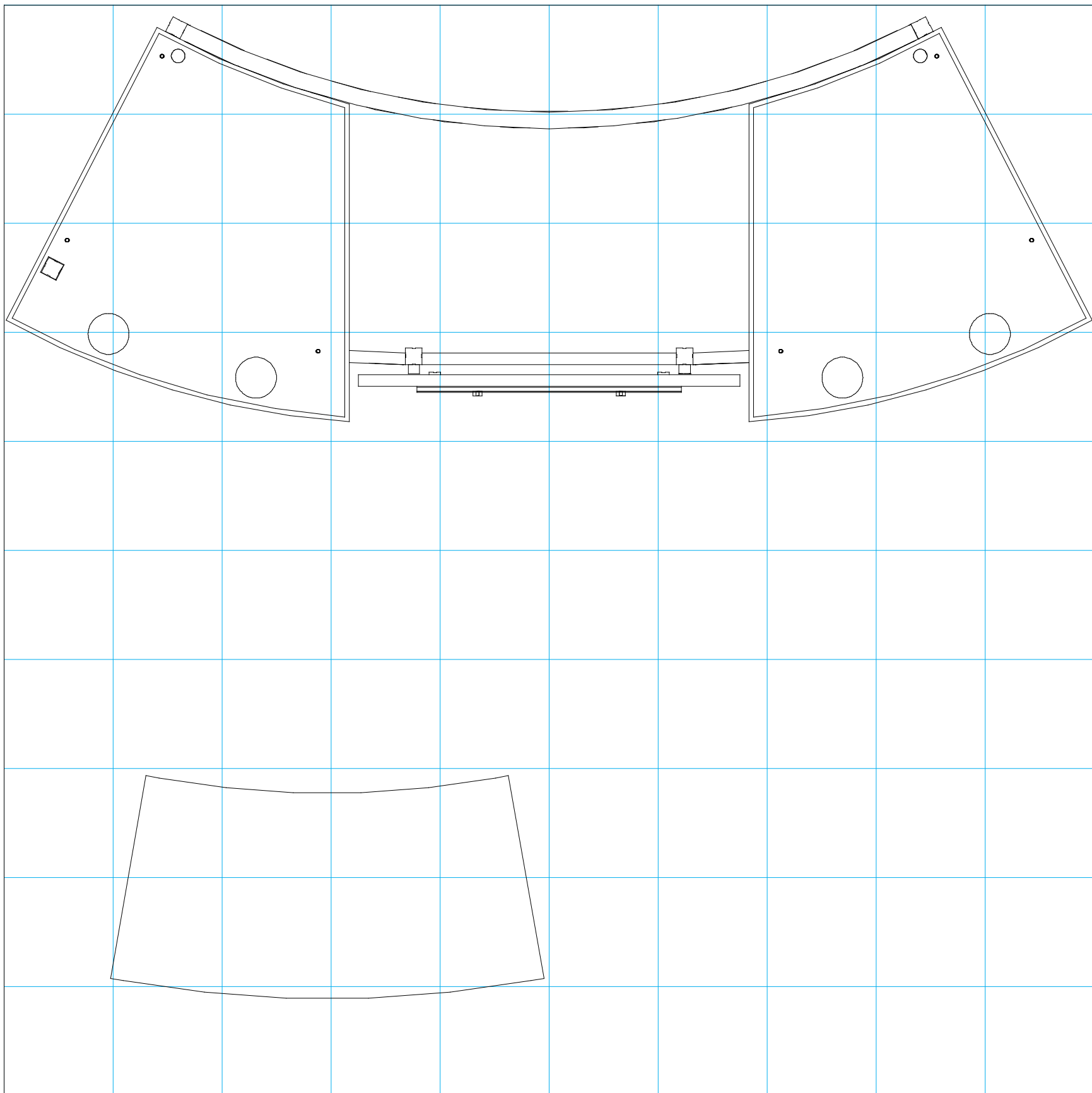

= 1 sq foot

## General Setup Instructions

- Read entire setup instruction manual prior to unpacking parts and pieces.
- The setup instructions are created specifically for this configuration.
- Setup instructions are laid out sequentially in steps, including exploded views with detailed explanation for assembly.

## Cleaning & Packing

- For Cleaning Metal, Plex, & Laminate Parts: Use a **MILD NON-ABRASIVE** cleanser and soft cloth/paper towel to clean all surfaces.
- Keep exhibit components away from heat and prolonged sun exposure.  
**Heat and UV exposure will warp and fade components.**
- Retain all provided Packing Materials. All provided packing materials are for ease of repacking & component protection.

## Disassembly

- For loss prevention, tighten all set screws and locks during disassembly.

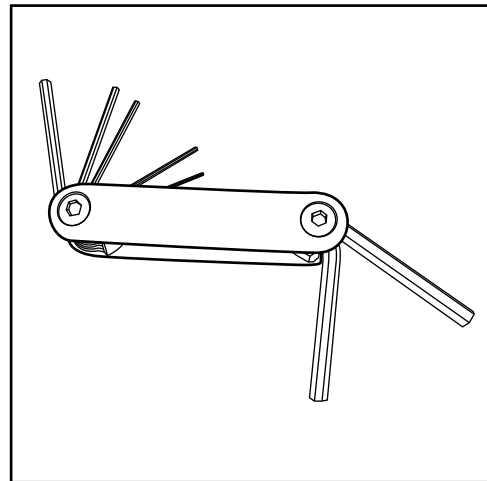

Hex Tool - Essential for Assembly

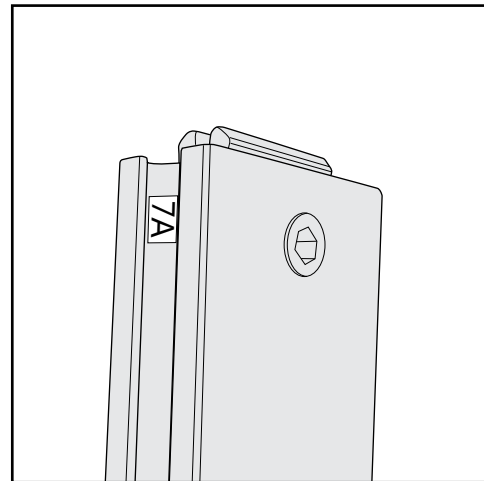

Part Identification - Numbering

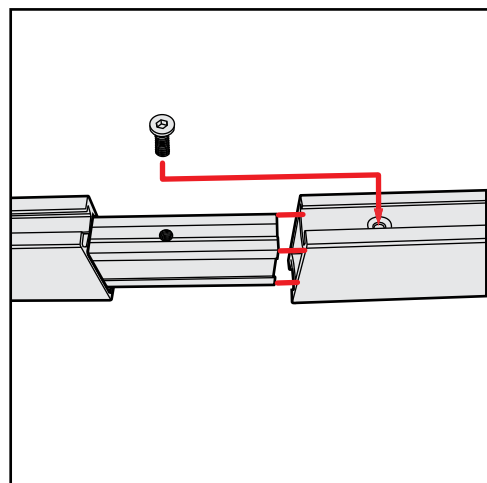

Spline Connection

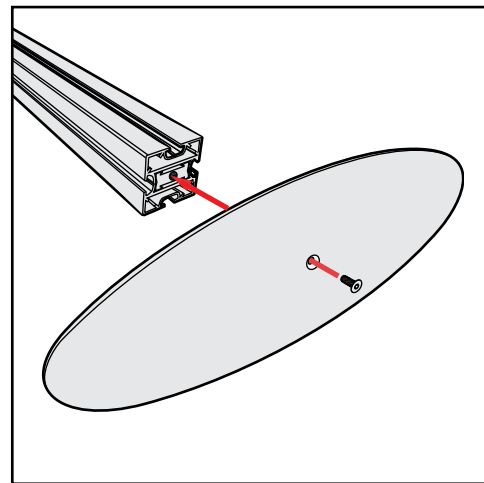

Base Plate & Extrusion Connection

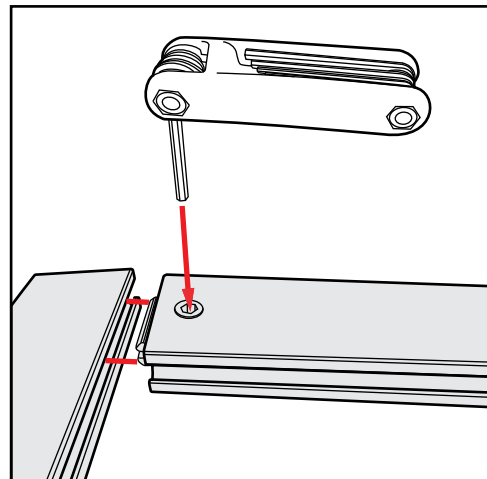

Extrusion & Lock Connection

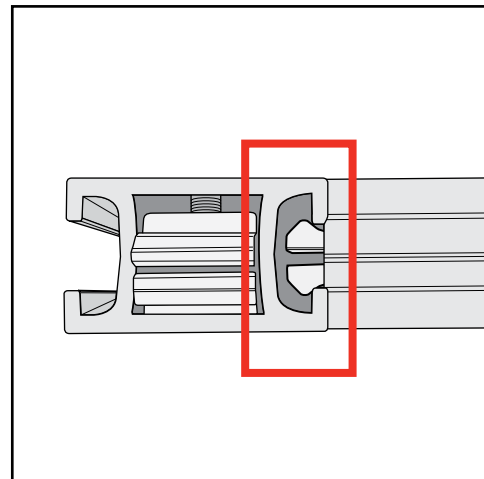

Engaged Lock



**WARNING**



DO NOT USE POWER TOOLS

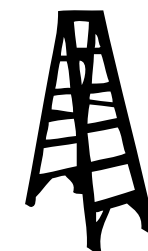

LADDERS OR LIFTS  
MAY BE REQUIRED



ALL CONNECTIONS MUST  
BE TIGHTLY SECURED

## Straight Connection

When assembling frame, first attach all **straight connectors**, then attach **corner connectors**.

- 1) Place extrusions end-to-end.
- 2) Loosen all knobs, then slide **straight connector** across the seam of extrusions.
- 3) Tighten all knobs to secure connection.

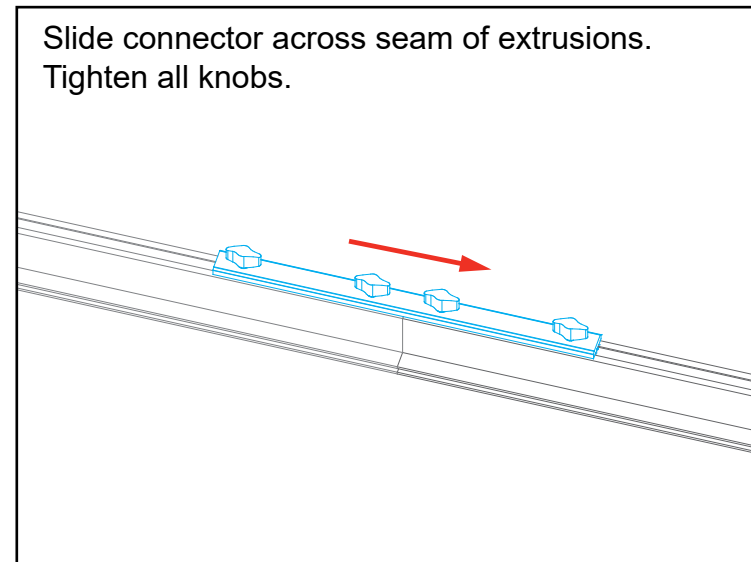
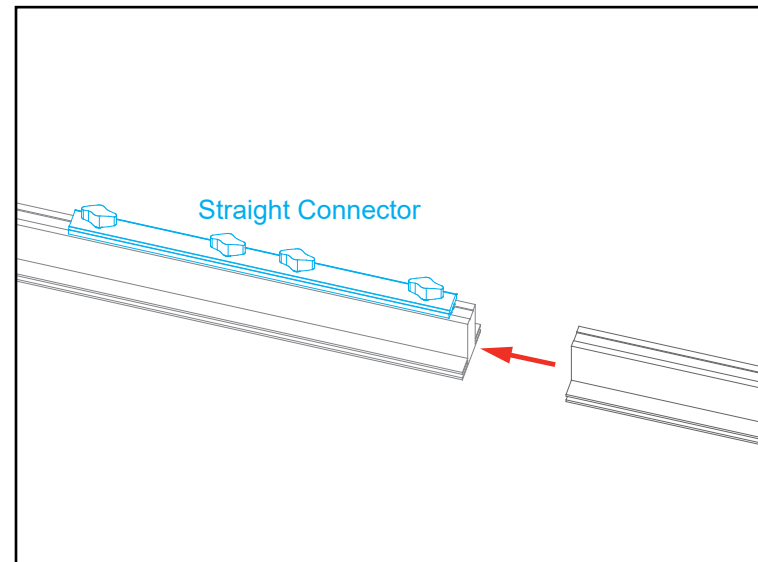

## Disassembly

- 1) Loosen all knobs.
- 2) Slide connectors off of one extrusion.
- 3) Tighten knobs to prevent loss during packing & shipping.

Keep straight connectors in groove of extrusion. Do not remove connectors during disassembly.

All knobs must be tightened securely to ensure a proper connection.

## Corner Connection

- 1) Loosen knobs, then slide vertical extrusions onto **corner connectors** of **lower** horizontal extrusion.
- 2) Slide **corner connectors** of **upper** horizontal extrusion into grooves of vertical extrusions.
- 3) Tighten all knobs to secure connection.

## Disassembly

- 1) Loosen knobs on vertical extrusions.
- 2) Slide the vertical extrusions off of **corner connectors** on lower and upper horizontal extrusions.

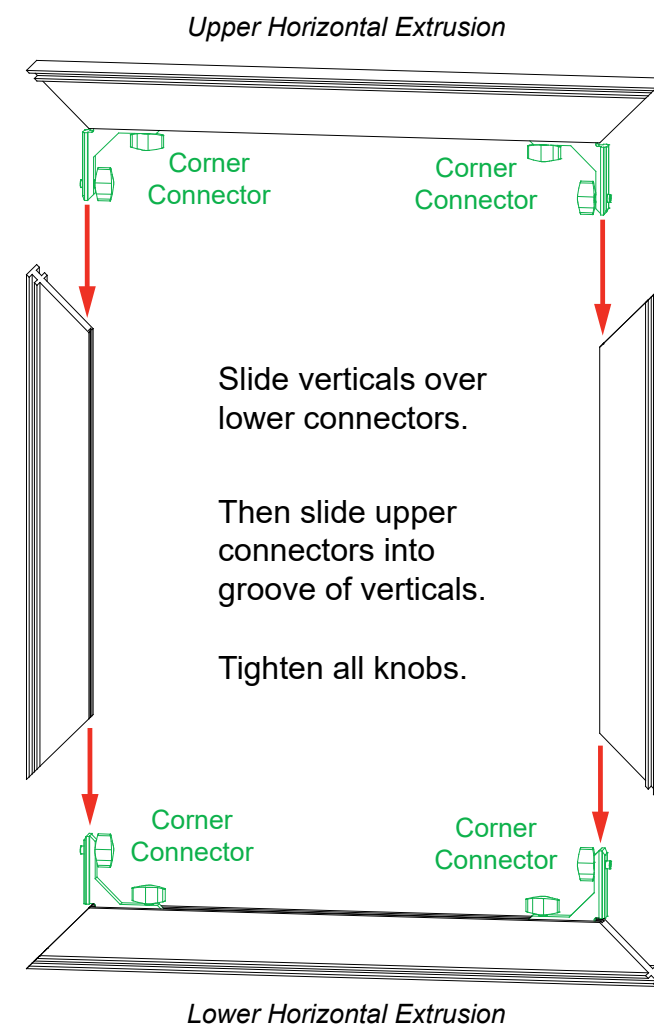

Adjust connectors if necessary to prevent gaps in connection.

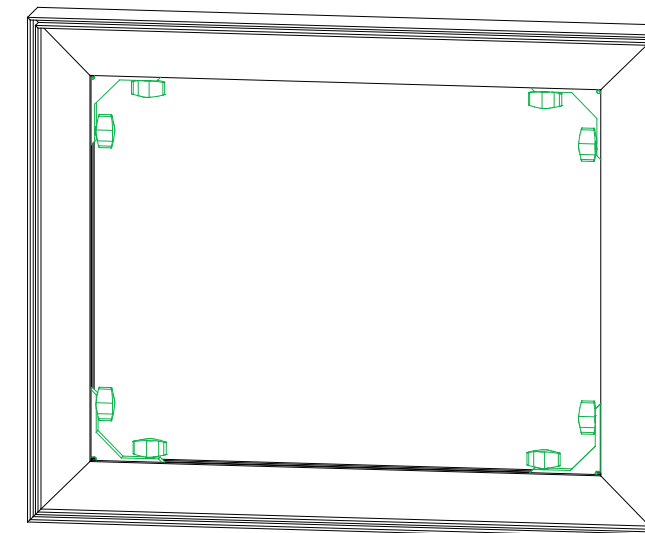

COMPLETED ASSEMBLY

All knobs must be tightened securely to ensure a proper connection.

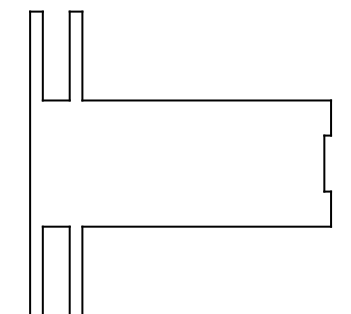

TSP49 Profile

# SEG Graphic Installation *in 3 Steps*

## STEP 1: Attach Corners

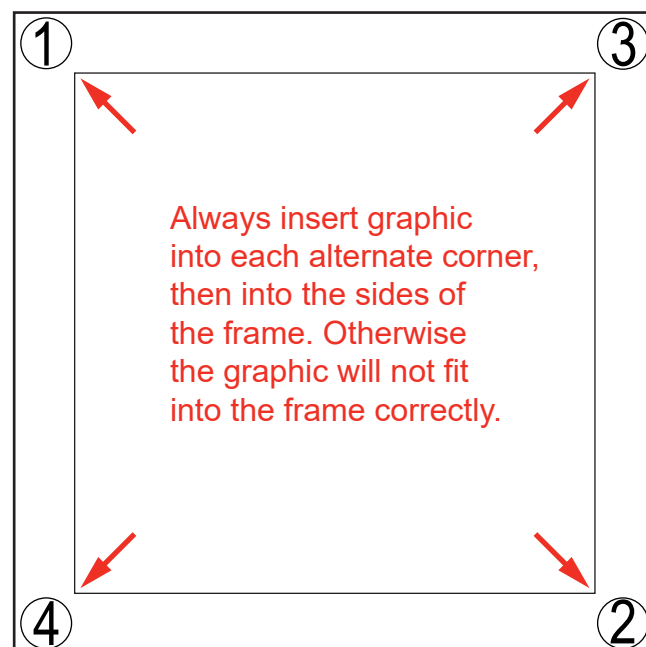

## STEP 2: Attach Middle

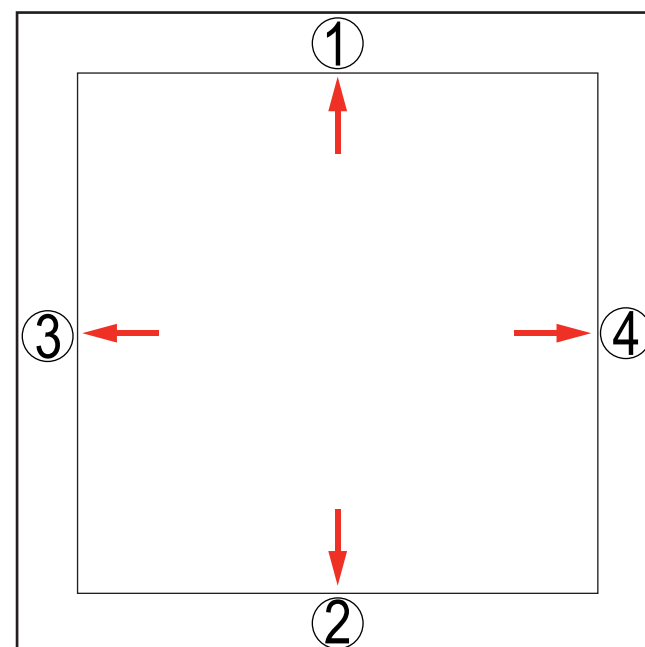

## STEP 3: Attach Sides

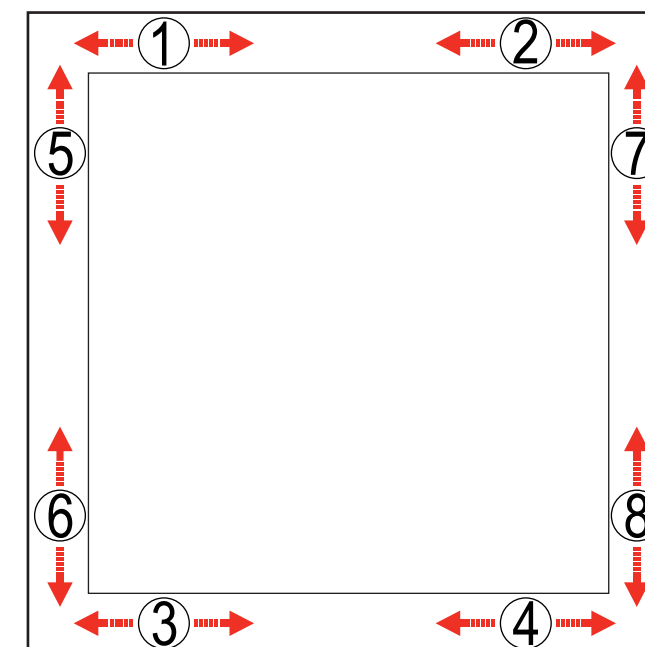

Insert narrow side of silicone welt into the channel at corner 1, with fabric to the outside.

Repeat for opposite corner 2, then corner 3, then corner 4.

Once corners are attached, press the middle of edge 1 into the channel. Then press middle of edge 2 into the channel on opposite side.

Repeat with edge 3 & 4.

Once the middle of sides are attached, fully press the silicone welt into the channel, between center and corner at location 1. Repeat the process between center and corner at location 2.

Do the same for welt on opposite side, at locations 3 & 4. Then repeat for locations 5 & 6 and 7 & 8.



Once the welt is fully inserted on all sides, smooth out edges as needed for a perfect fit.

To remove the graphic from the frame, locate the fabric **pull tab**. Gently pull on the tab to remove the graphic.

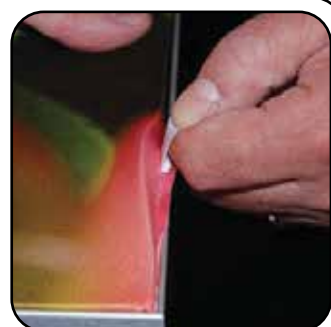

Install video:



# euro lt | HYBRIDS

## Using Your Setup Instructions

The Euro LT Hybrids Setup Instructions are created specifically for your configuration. They are laid out sequentially in levels, including exploded views, and a logical series of detailed steps to assemble the main structure and components. We encourage you to study the instructions **before** attempting to assemble your exhibit.

Each page reminds you to tighten the setscrews after disassembling your exhibit to prevent loss of the locks and setscrews (see below in RED). This is VERY IMPORTANT.

## Cleaning and Packing Your Display

- 1) Use care when cleaning aluminum extrusion or acrylic inserts. Use only non-abrasive cleaners.
- 2) When cleaning laminate inserts, countertops, or panels use mild cleansers and a soft material such as cotton.
- 3) Keep all display components away from extreme heat and long exposure to sunlight to avoid warping and fading.
- 4) Retain all packing material. It will make re-packing much easier and will reduce the likelihood of shipping damage.

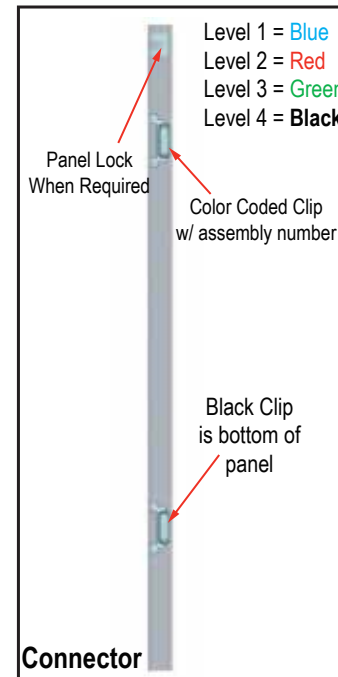

Each component has 2 clips, the lower clip is ALWAYS black. The top clip is color coded to distinguish which level. The color coded clip also contains the numbered label.

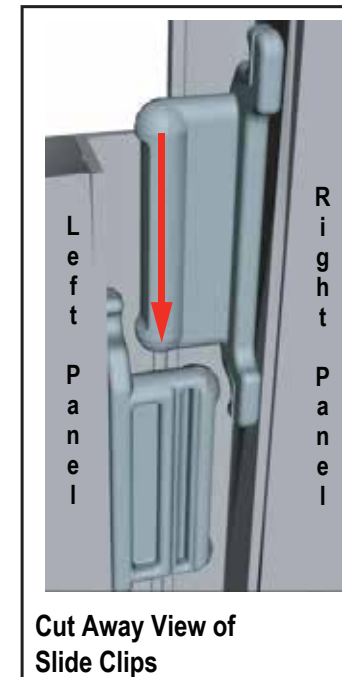

Components connect together by aligning them and sliding downward connecting clips together.

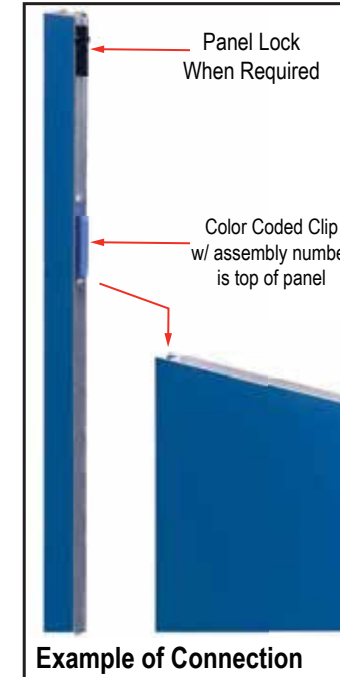

Configurations are assembled from left to right, usually starting with #1 and following the numbered sequence.

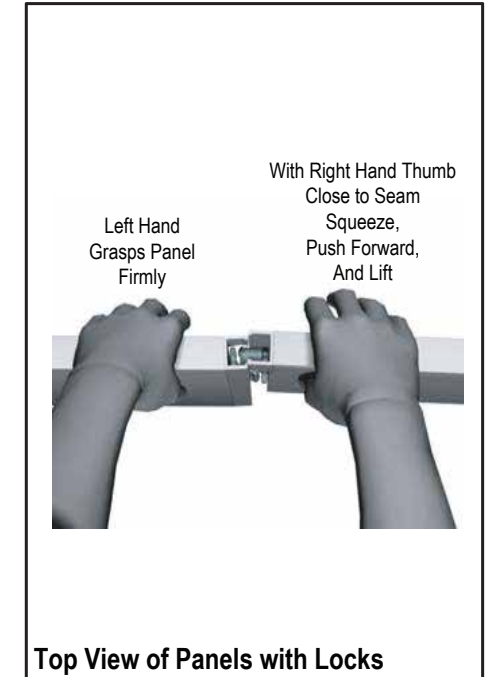

The first level of components contain panel locks that are located at the top of the panel for extra stability and seamless connection. When disassembling panels twist top connection slightly and lift right panel upward.

## General Setup Instructions for Extrusion System



Most exhibits can be assembled with the supplied Hex Key Tool. Occasionally, a flat head screwdriver may be required.



Most horizontal extrusion connections have a patented expandable lock. This lock inserts into the groove of an opposing extrusion. Tightening the lock with the Hex Key Tool expands the lock and creates a strong positive connection.

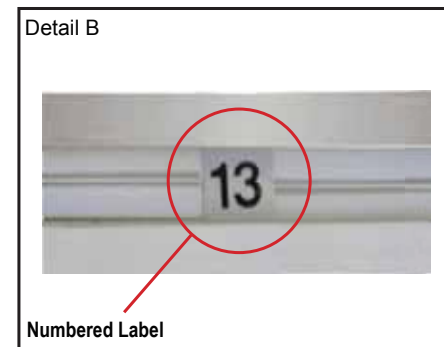

Each extrusion contains a numbered label which corresponds with setup instructions. The label is located within a groove of the extrusion (when possible). With extrusion components the labels contain Black numbers unless otherwise specified.

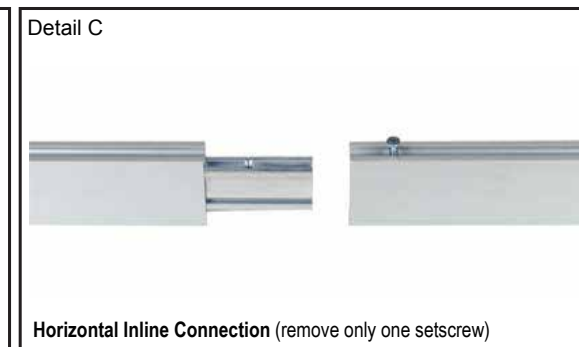

Remove only (1) setscrew when disassembling. Replace setscrew in extrusion after assembling it. Before packing, replace setscrew in extrusion to avoid losing it.

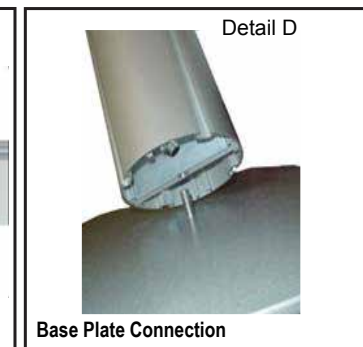

Attach base plate to round or square vertical extrusion using the bolt provided. Be careful not to strip the threads.

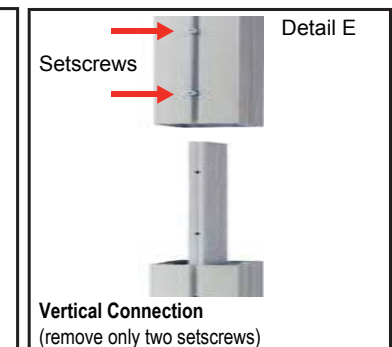

When vertical extrusions are packed in portable cases rather than crates or tubs, they must be broken down into smaller sections which then require assembly.

Remove only (2) setscrews when disassembling. Replace setscrews in extrusion after assembling it. Before packing, replace setscrews in extrusion to avoid losing them.

CRATE PACKING

Item	Qty.	Description
1,1A	1,1	92" TSP46 Vertical Extrusion
2,2A	1,1	39.7375" TSP46 Curved Horizontal Extrusion
3,3A	1,1	92" TSP46 Vertical Extrusion
4,4A	1,1	28" TSP46 Curved Horizontal Extrusion
5	1	92" S44 Vertical Extrusion
6	1	92" S44 Vertical Extrusion
7	1	92" S44 Vertical Extrusion
8	1	92" S44 Vertical Extrusion
9,9A	1,1	92" TSP49 Vertical Extrusion
10,10A	1,1	84.4392" TSP49 Curved Horizontal Extrusion
11	1	92" S44 Vertical Extrusion
12	1	92" S44 Vertical Extrusion
13	1	88.417" Z33 Vertical Extrusion

**Steps:**

Assemble frames flat on floor, then raise upright to attach verticals [5] [6] [7] [8] [11] and [12].

- 1) Assemble front frames as shown. See [Tool-less Corner Connection](#) detail.
- 2) Attach front frames between verticals [5] [6] [7] and [8]. See [Custom Cam Lock](#) detail.
- 3) Assemble back frame as shown. See [Tool-less Corner Connection](#) detail.
- 4) Attach back frame between verticals [11] and [12]. See [Custom Cam Lock](#) detail.

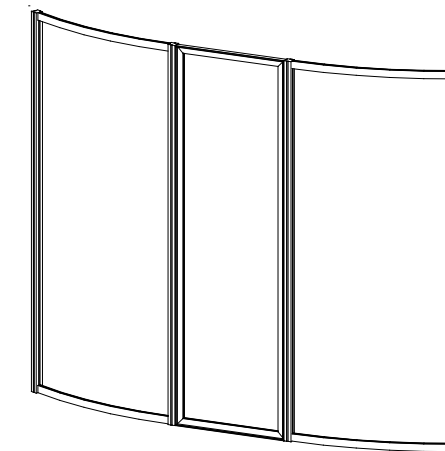
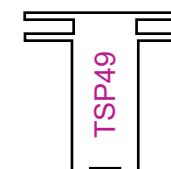
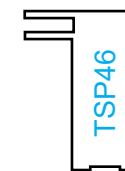

Completed Front Frames

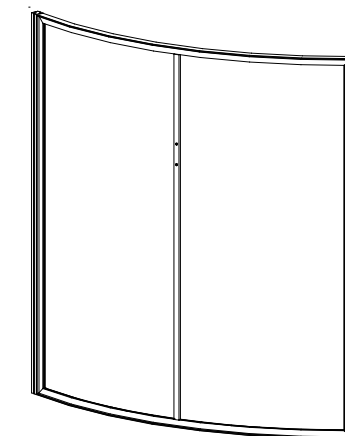

Completed Back Frame

**\* Tool-less Corner Connector**

1. Slide extrusion onto Corner Connector.
2. Tighten all knobs to secure connection.

*Keep corner connectors attached to horizontal extrusions.*

**\* Custom Cam Lock for TSP49**

Tighten screw to clamp cam lock into groove of vertical extrusion.

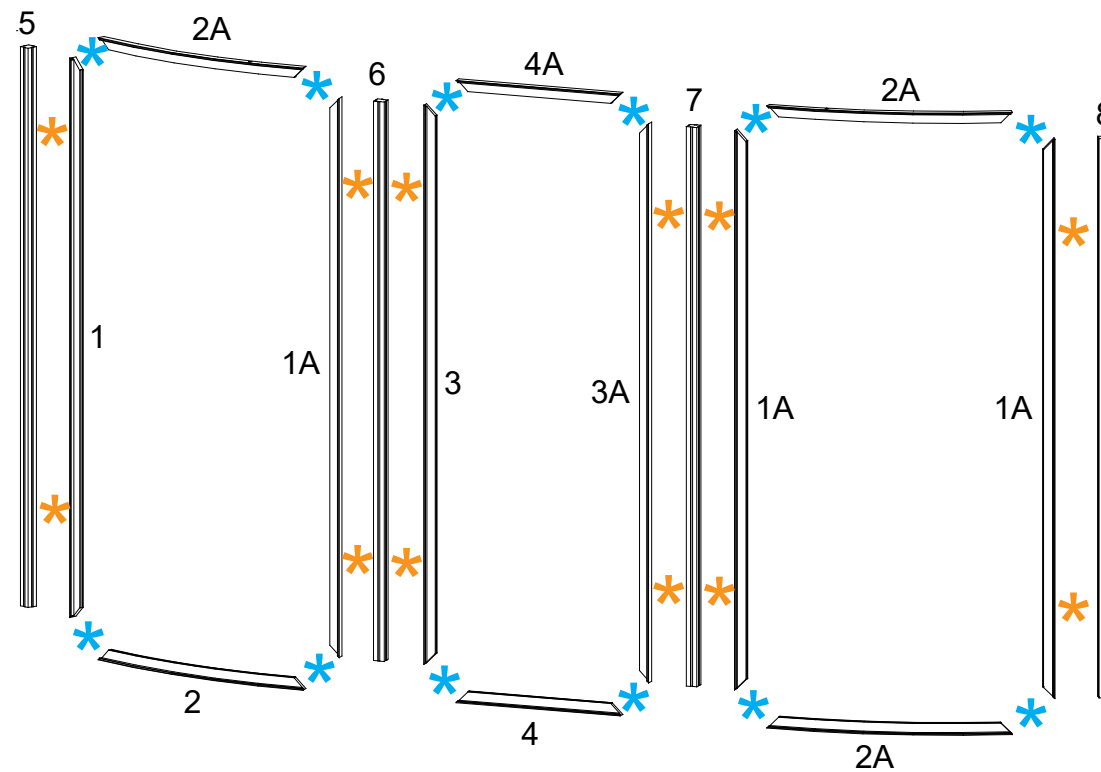

Front Frames

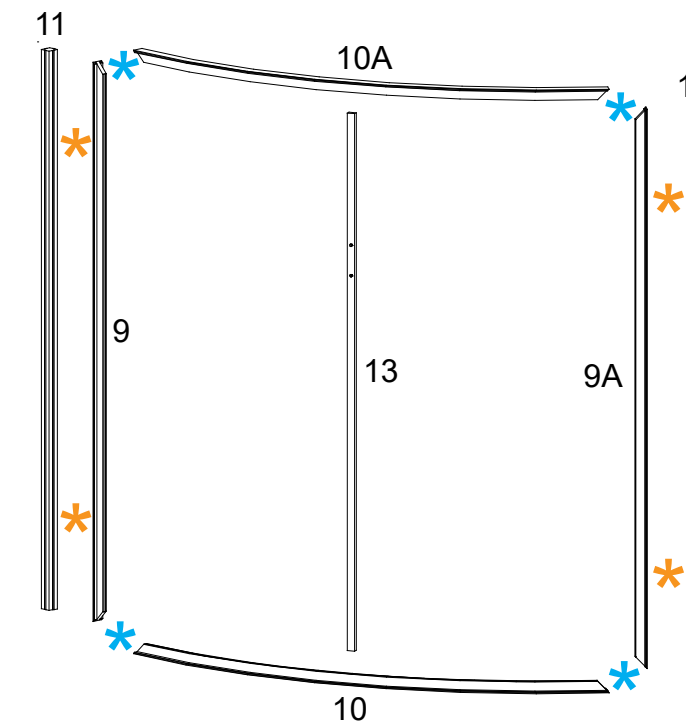

Back Frame



Item	Qty.	Description
15	2	28" Z45 Horizontal Extrusion
14	2	28" Z45 Horizontal Extrusion
--	1	Door Threshold

**Steps:**

- 1) Attach door threshold between verticals [8] and [12].  
See [Door Threshold](#) detail.
- 2) Attach horizontal [14] between verticals [5] and [11], then slide infill between verticals.
- 3) Attach horizontal [14] between verticals [8] and [12], then slide infill between verticals
- 4) Secure infills with horizontals [15].
- 5) Connect door to vertical [12]. See [Door Connection](#) detail.
- 6) Apply SEG graphics to front and back frames.  
See SEG Graphic Installation sheet for instruction.

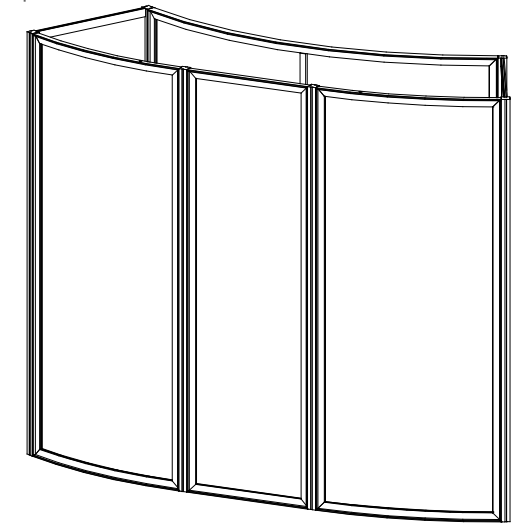

**Completed Closet Assembly**

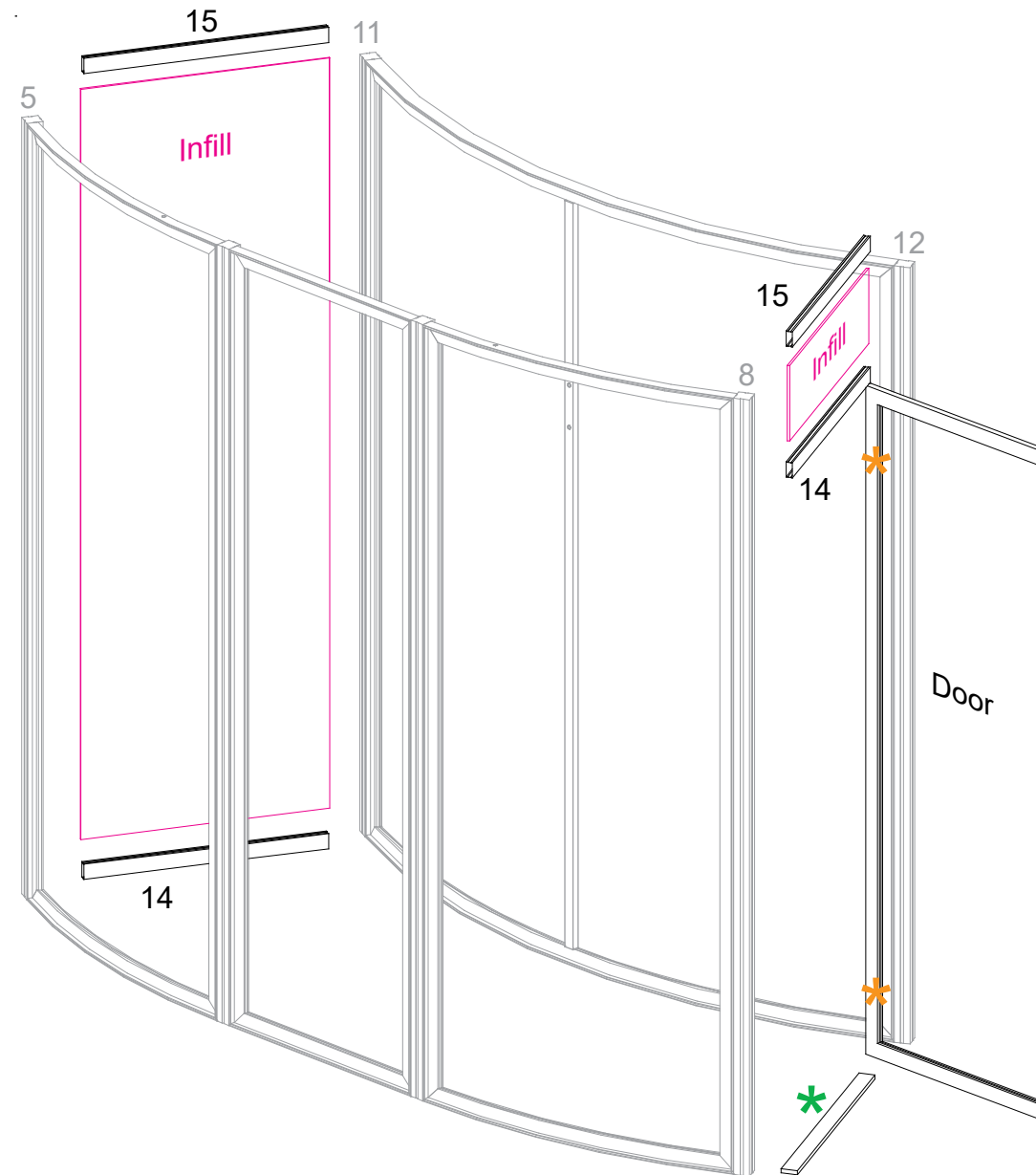

**Keep side extrusions [8] [12] [14] [15] and door assembled when packing.**

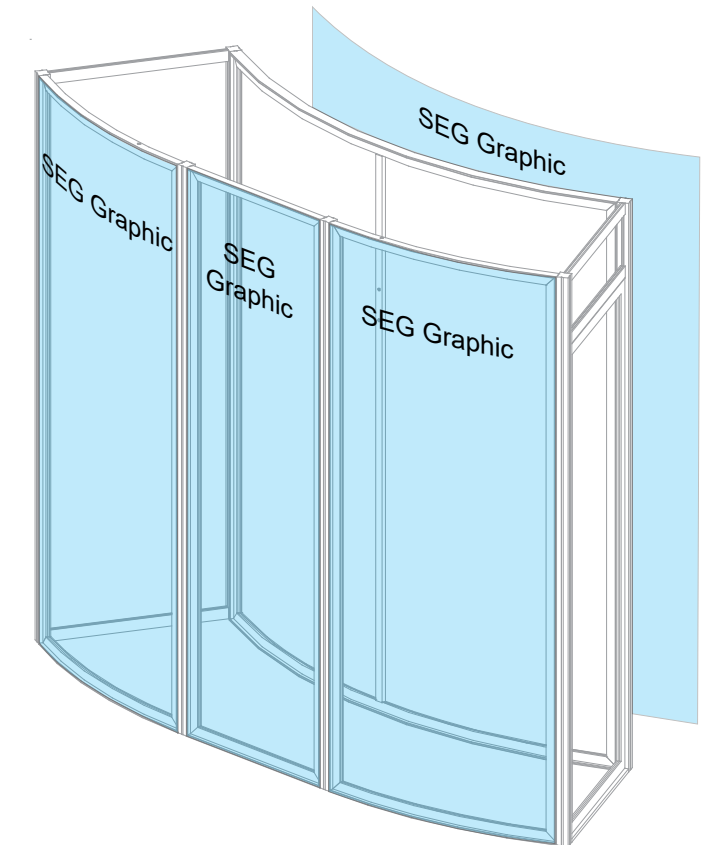
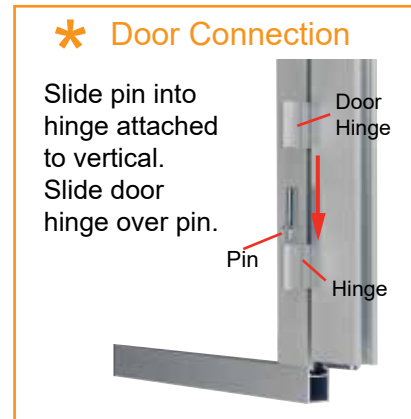
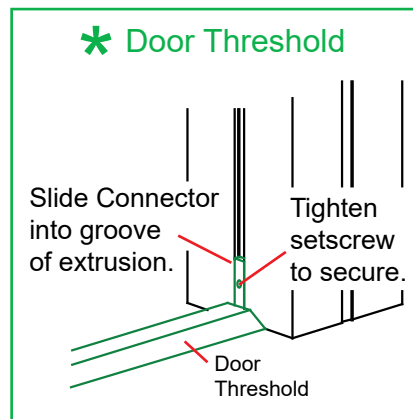

Item	Qty.	Description
16,16A	1,1	90" TSP46 Vertical Extrusion
17,17A	1,1	42" TSP46 Horizontal Extrusion
18	1,1	38.417" Z140 Horizontal Extrusion
19	1	38.417" Z45 Horizontal Extrusion

**Steps:**

- 1) Connect horizontals [17] and [17A] between verticals [16] and [16A]. See **Tool-less Corner Connection** detail.
- 2) Attach horizontals [18] and [19] between verticals [16] and [16A].
- 3) Attach frame assembly to closet verticals [6] and [7], using 1" standoff barrels and 5/16 - 1 1/4" bolts.
- 4) Attach monitor mount to horizontal [18]. See **Monitor Mount Attachment** detail.
- 5) Install SEG graphic to front of assembled frame. See SEG Graphic Installation sheet for instruction.

Keep front frame [16] [16A] [17] [17A] [18] and [19] assembled when packing.

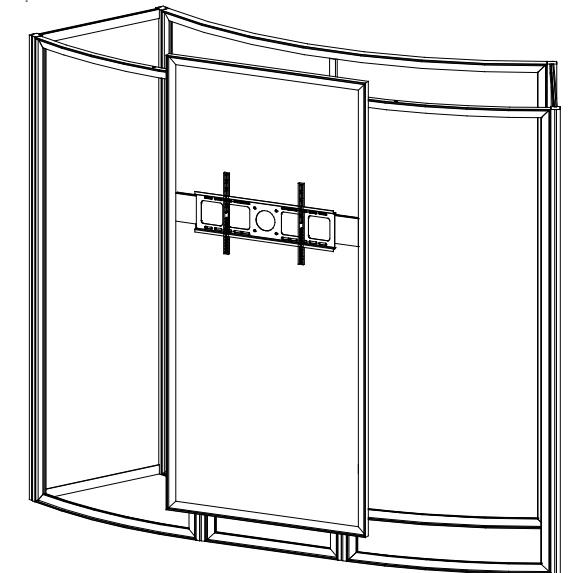
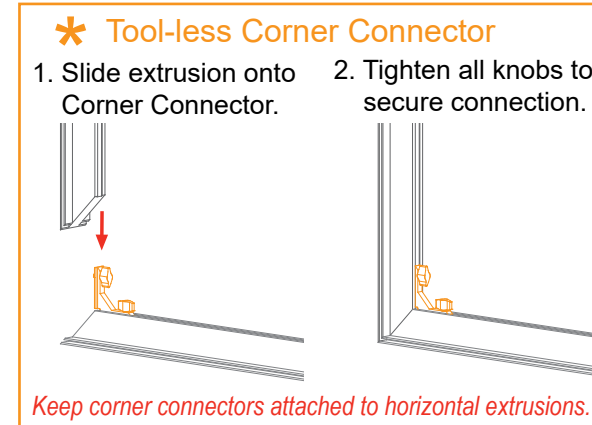

Completed Closet Assembly with Front Frame

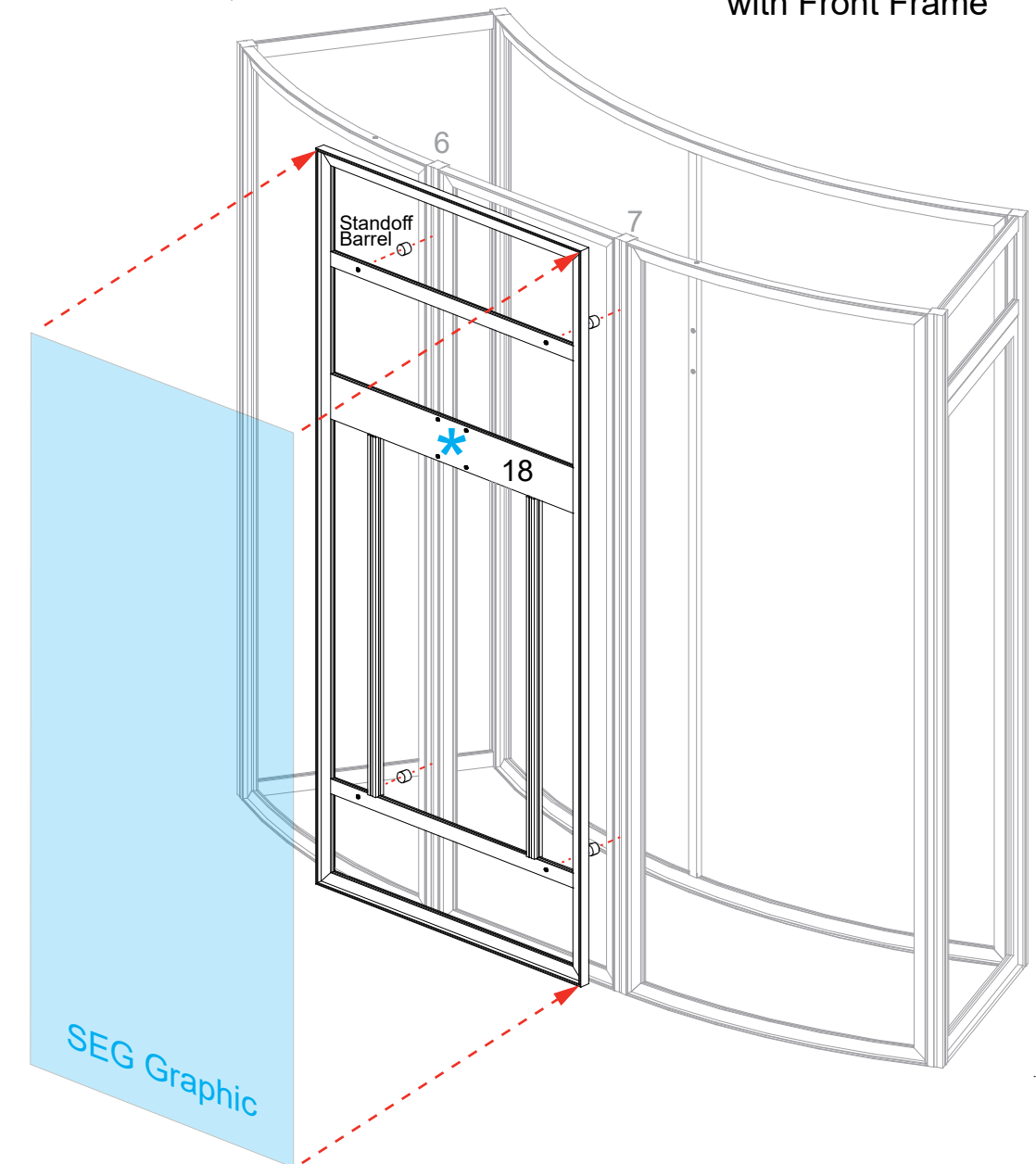
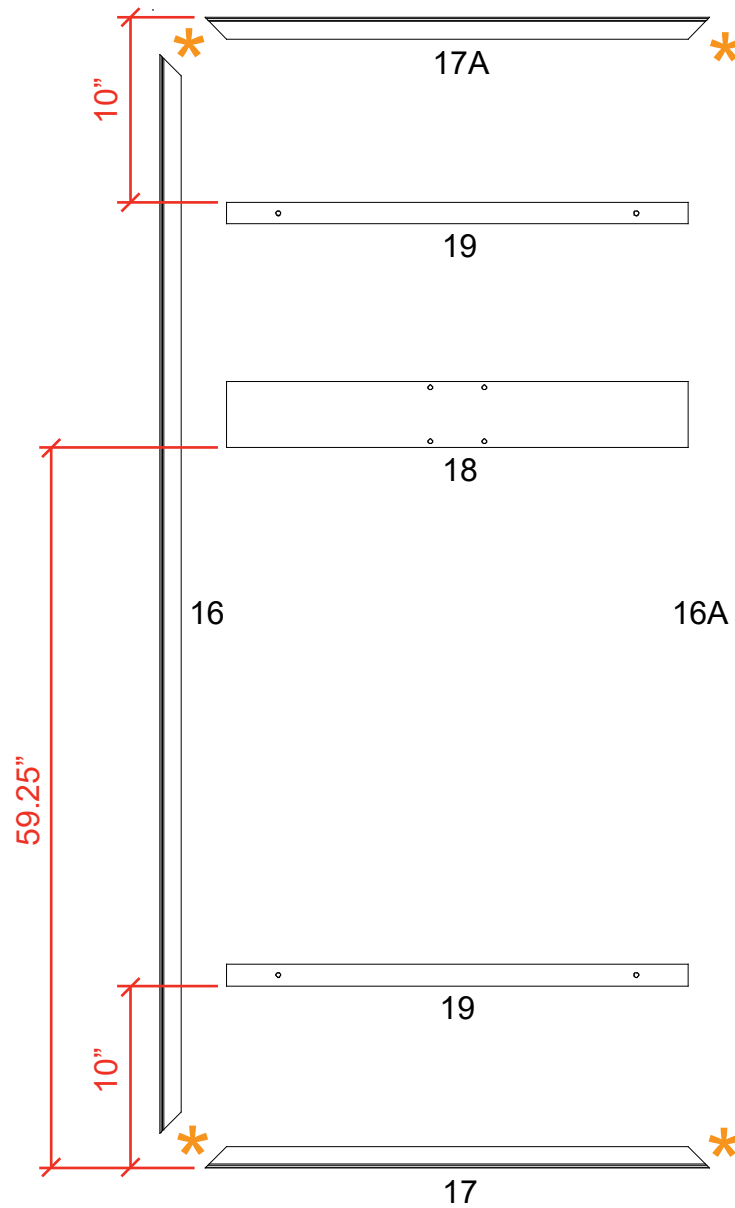
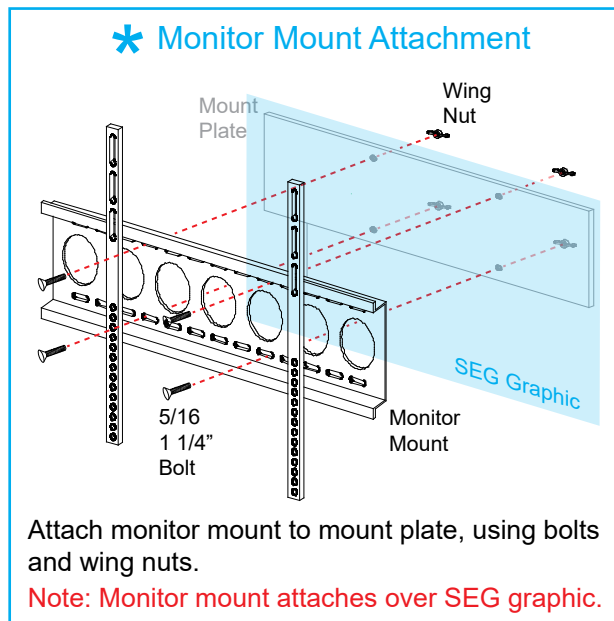

**Steps:**

- 1) Attach ceiling panels to top of assembled closet  
See Ceiling Connection details.
- 2) Connect power cords to puck lights in ceiling panels.  
See **Puck Light Connection** detail. Use holes in ceiling panels for cord management.

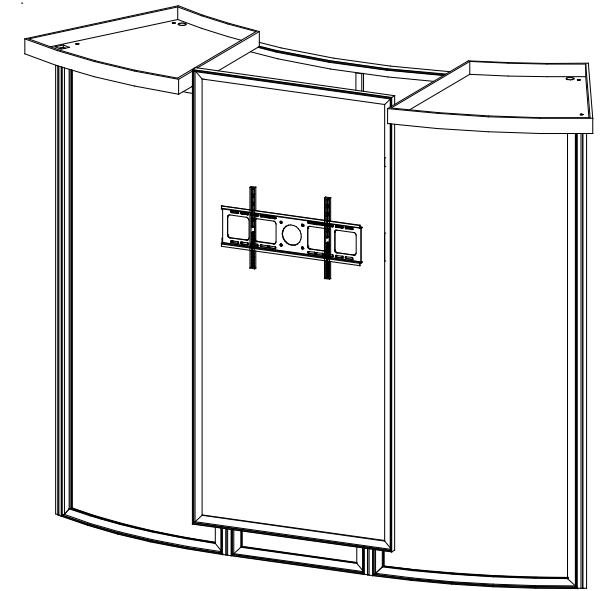
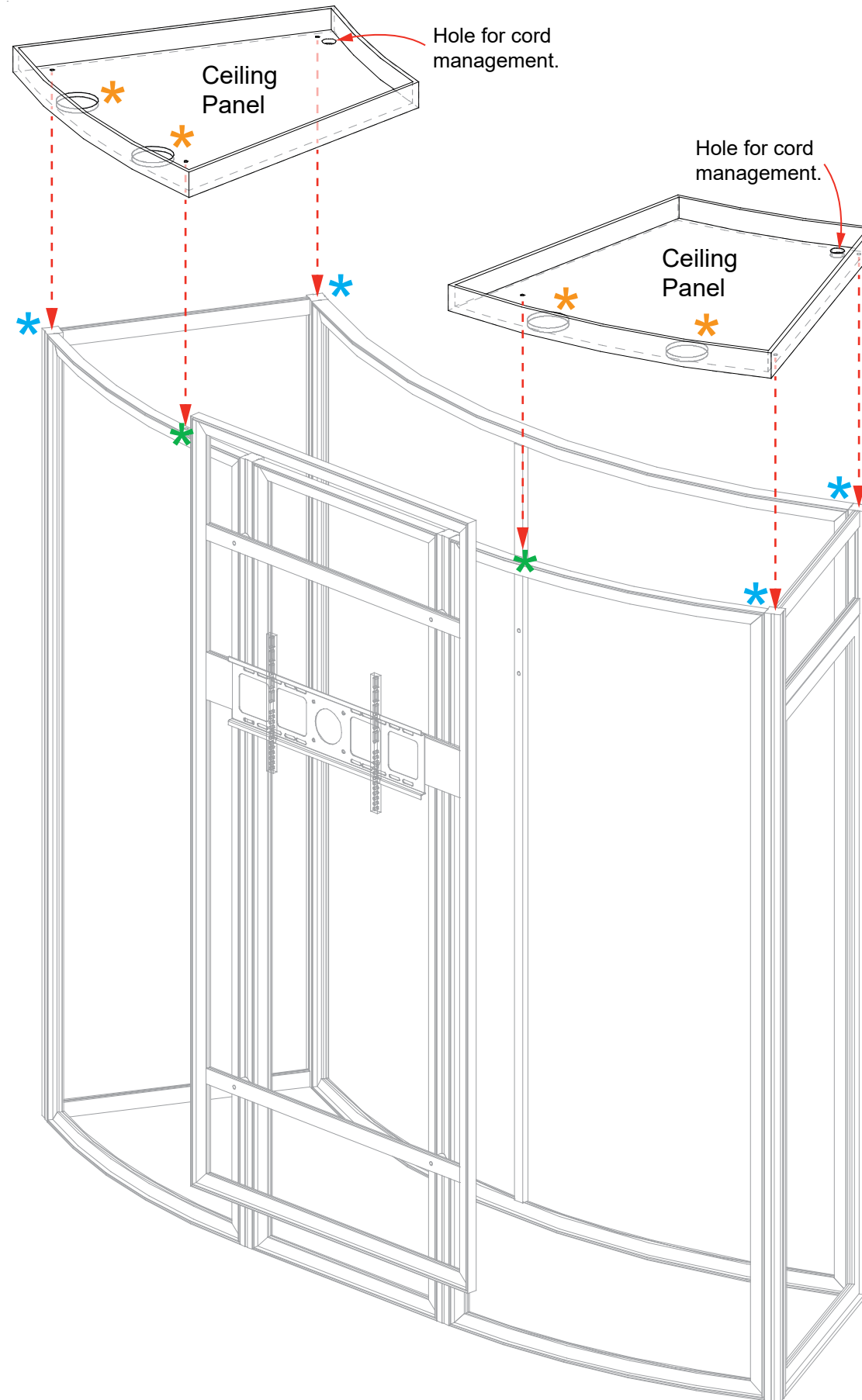
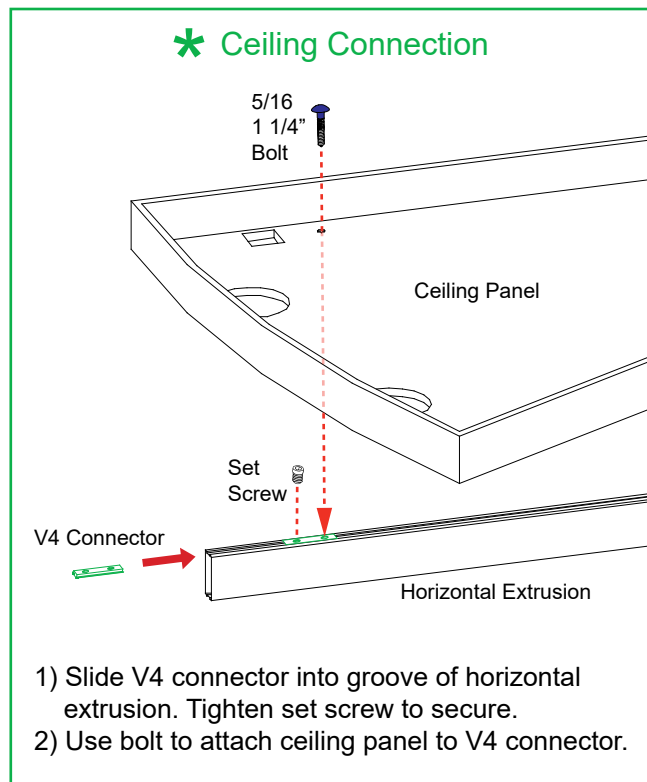
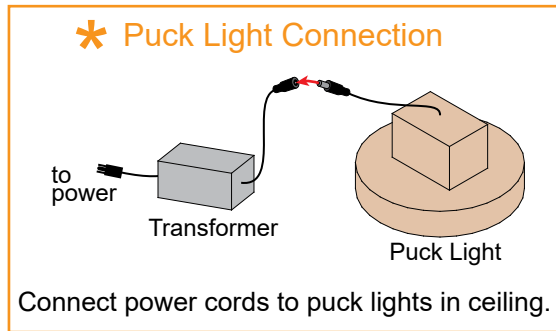

**Completed Assembly**

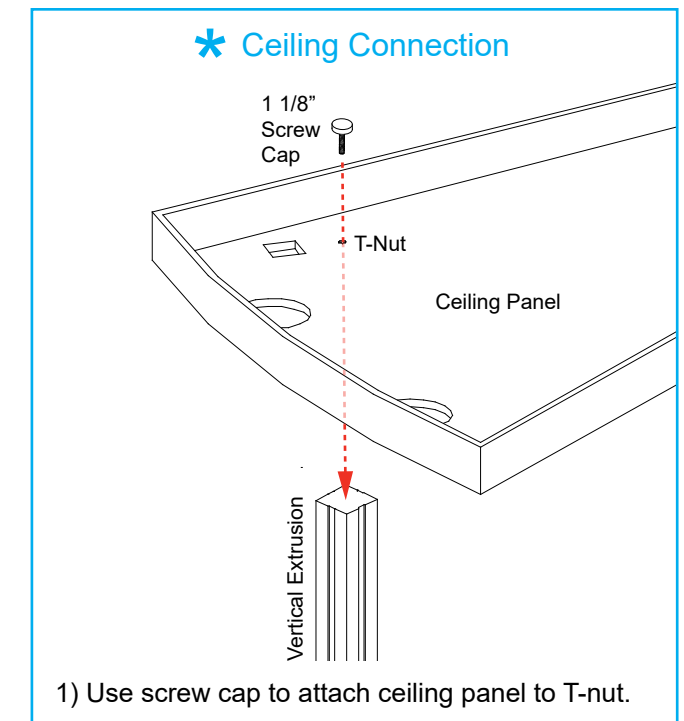

Item	Description
1	38" 90° LT Connector
2	36.9738" x 38" Curved LT Panel w/ Door
3	38" 90° LT Connector
4	19"w x 38"h LT Panel
5	38" 90° LT Connector
6	44.13"w x 38" LT Panel
7	38" 90° LT Connector
8	19"w x 38"h LT Panel

Steps:

- 1) Assemble LT panels and connectors in numerical order, making sure Velcro is facing inward.
- 2) Attach shelf supports to Velcro on panels [4] and [8], then place internal shelf on top of supports.
- 3) Lock counter top to panels [4] and [8]. See Counter Top Lock detail.

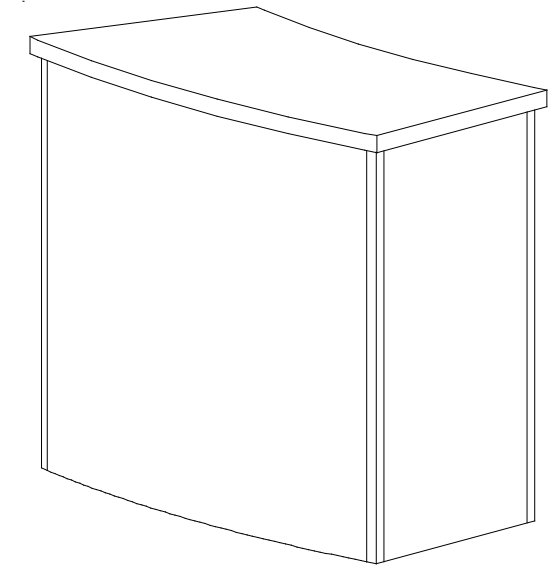
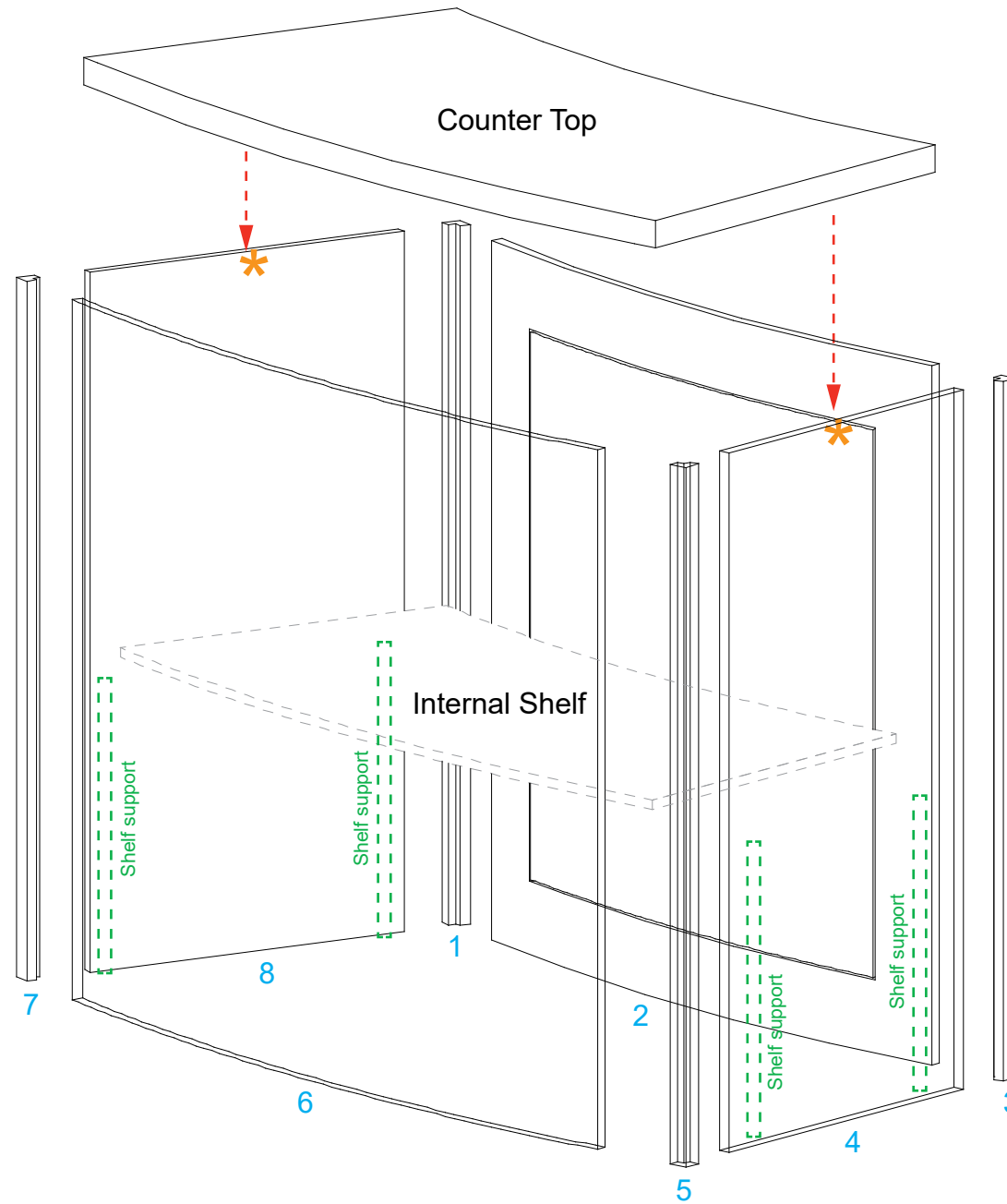
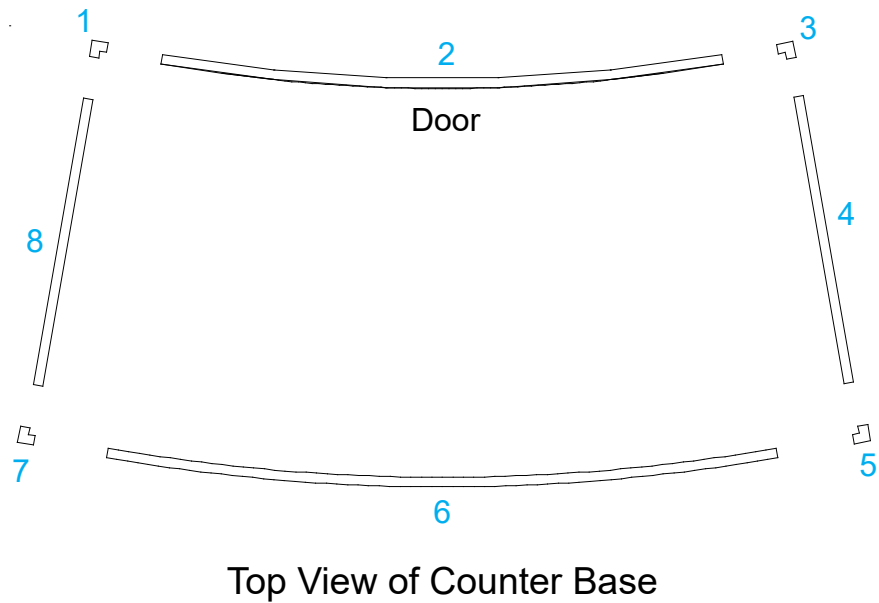

Completed Reception Counter

